

SRN BEARINGS PRIVATE LIMITED



LMF..L/ LMEF..L



LMK..L/LMEK..L



LMH..L



ST



KH



LM..L/LME..L



LM/LMB/LME



LM..LMB../LME..AJ



LM../LMB../LME..OP



Linear Bearing Catalogue



FACTORY

LYCLOKI





Linear Bearing



TBR Linear Bearing



SBR Linear Bearing



LM Linear Bearing



LM_L Linear Bearing



LM_AJ Linear Bearing



LMF Linear Bearing

Specification :

1.Color:silver

2.Linear bearing material:bearing steel Gcr15

3.Applied In:mechanic

4.Smooth movement,low friction, high rigidity and long life

5.We can make non-standard linear bearing according to clients samples of drawing.

6.prompt delivery

7.we supply OEM service.

8.Nice appearance,complete product system.



Linear Bearing



LMF_L Linear Bearing



LM_OP Linear Bearing



LMK Linear Bearing



LMK_L Linear Bearing



LMH Linear Bearing



LMH_L Linear Bearing

LM metric standard type linear bearing

LME means inch standard type linear bearing

UU rubber seals on the both sides of the long type linear bearing

OP means open type linear bearing

AJ means adjustment type linear bearing

•LM...UU: LM...(sylinder), LM...OP (open type), LM...AJ (clearance adustable)

•LME...UU: LME...(sylinder), LME...OP(open type), LME...AJ(clearance adustable), LM...UU & LME...UU: Long type

•KH: High-precision mini bearing



Linear Bearing

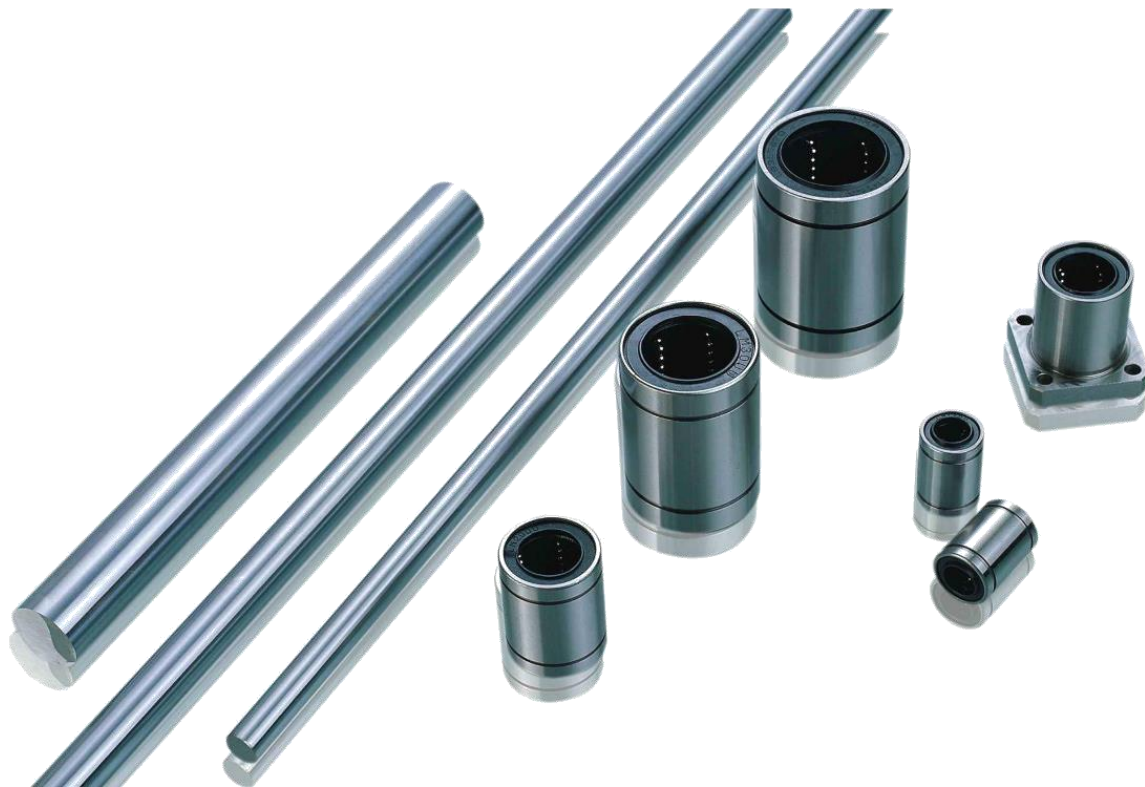

LMFP Linear Bearing



LMFP_L Linear Bearing



LMKP Linear Bearing



LMKP_L Linear Bearing



LMHP Linear Bearing



LMHP_L Linear Bearing



LMFM Linear Bearing



LMKM Linear Bearing



LMHM Linear Bearing

linear bearing TBR SERIES



● Drawing

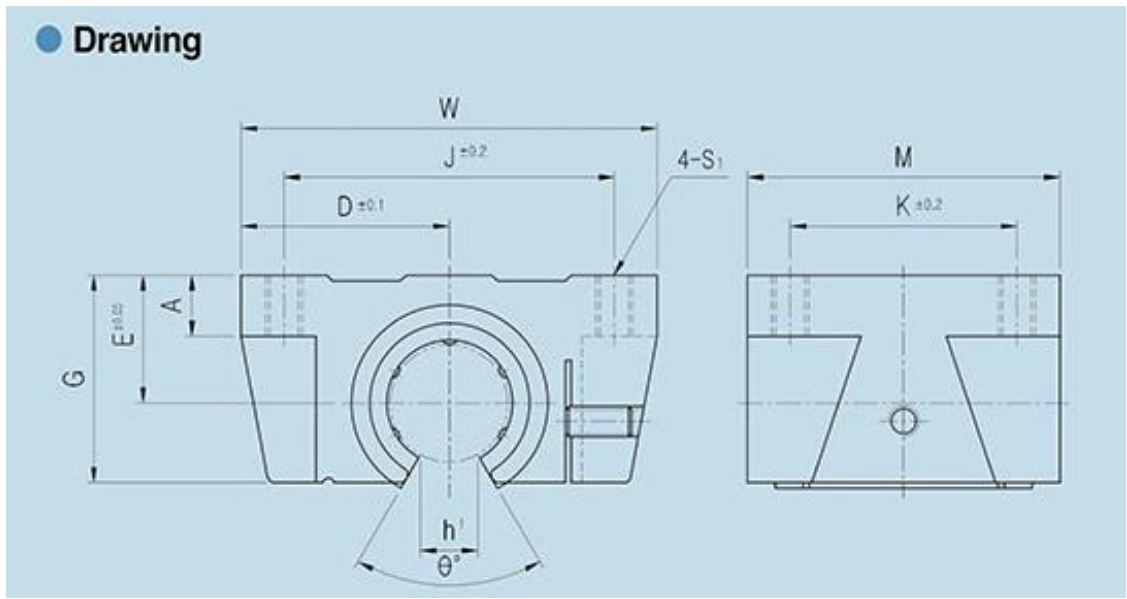

● Part Number Notation

TBR 20 UU N S

● Aluminum Case Unit(Open type)

● Nominal Shaft Diameter

● Seal

Blank	No Seal
UU	Both Side Seal
U	One Side Seal

● Outer-sleeves (by corrosion resistance)

Blank	Standard(SUJ2)
N	Electroless nickel plating
R	Raydent treatment

● Ball type (material)

Blank	High carbon bearing steel ball(Standard)
S	Stainless steel ball



PART NUMBER	LB	D	W	G	θ	A	M	S ₁	h ₁	E	J	K	BASIC LOAD RATING(N) ^{★1}		WEIGHT (gf) ^{★2}
													DYNAMIC (C) ^{★1}	STATIC (C ₀)	
TBR16UU	LM16UUOP	31	62	26	80°	8	42	M5	11	18	50	30	392	490	180
TBR20UU	LM20UUOP	34	68	31	60°	10	51	M6	11	21	54	37	784	1176	300
TBR25UU	LM25UUOP	41	82	41	50°	12	65	M8	12	28	65	50	1568	2352	600
TBR30UU	LM30UUOP	45.5	91	48	50°	12	75	M8	15	34	75	60	1764	2940	900

- ★1 Dynamic load rating is based on the nominal life of 50km
In case of 100km, C on the table need to be divided by 1.26
Ex) 50km basic dynamic load rating(C) of TBR16UU = 392N
100km basic dynamic load rating(C₁₀₀) of TBR16UU = 392/1.26 = 311.11N
- ★2 Based on the weight of resin retainer
- ★3 Main unit : mm
- ★4 1N ≒ 0.102kgf

linear bearing SBR SERIES



● Drawing

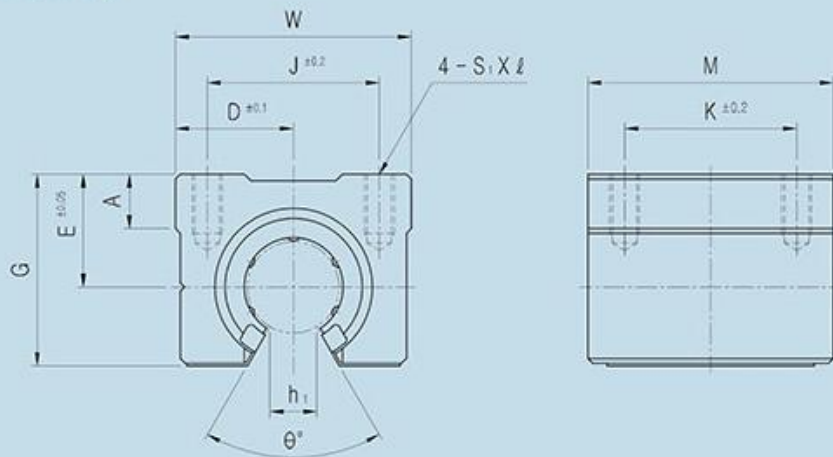

● Part Number Notation

SBR 20 UU N S

- Aluminum Case Unit(Open type)
- Nominal Shaft Diameter
- Seal

UU	Both Side Seal *1
----	-------------------
- Outer-sleeves (by corrosion resistance)

Blank	Standard(SUU2)
N	Electroless nickel plating
R	Raydent treatment
- Ball type (material)

Blank	High carbon bearing steel ball(Standard)
S	Stainless steel ball



- *1 UU type only available.
No seal type & One side type not available.
- * Resin retainer only applicable

PART NUMBER	LB	D	W	G	θ	A	M	S ₁ X l	h ₁	E	J	K	BASIC LOAD RATING(N)**		WEIGHT (gf)**2
													DYNAMIC (C)**1	STATIC (C ₀)	
SBR16UU	LM16UUOP	22.5	45	33	80°	9	45	M5x12	11	20	32	30	770	1170	150
SBR20UU	LM20UUOP	24	48	39	60°	11	50	M6x12	11	23	35	35	860	1370	200
SBR25UU	LM25UUOP	30	60	47	50°	14	65	M6x12	12	27	40	40	980	1560	450
SBR30UU	LM30UUOP	35	70	56	50°	15	70	M8x18	15	33	50	50	1560	2740	630
SBR35UU	LM35UUOP	40	80	63	50°	18	80	M8x18	17	37	55	55	1660	3130	920
SBR40UU	LM40UUOP	45	90	72	50°	20	90	M10x20	20	42	65	65	2150	4010	1330
SBR50UU	LM50UUOP	60	120	91	50°	25	110	M10x20	25	53	94	80	3820	7930	3000

- *1 Dynamic load rating is based on the nominal life of 50km
In case of 100km, C on the table need to be divided by 1.26
Ex) 50km basic dynamic load rating(C) of SBR16 = 770N
100km basic dynamic load rating(C₁₀₀) of SBR16 = 770/1.26 = 611.11N
- *2 Based on the weight of resin retainer
- *3 Main unit : mm
- *4 1N ≒ 0.102kgf

linear bearing LM SERIES



PART NUMBER		WORKING BORE DIAMETER		D		L		B		W	D ₁	BASIC LOAD RATING(N) ^{*1}		NO. OF BALL ROW	WEIGHT (gf) ^{*2}
Resin	Steel ^{*5}	dr. (mm)	CLEAR NCE(mm)	mm	CLEAR NCE(mm)	mm	CLEAR NCE(mm)	mm	CLEAR NCE(mm)			DYNAMIC (C) ^{*1}	STATIC (Co)		
LM5UU		5	0 -0.008	10	0 -0.008	15	0 -0.12	10.2		1.1	9.6	167	206	4	4
LM6UU	LM6-A	6		12		19		13.5		1.1	11.5	200	260	4	8
LM8SUU		8		15	0 -0.011	17		11.5		1.1	14.3	170	220	4	11
LM8UU	LM8-A	8		15		24		17.5		1.1	14.3	260	400	4	16
LM10UU	LM10-A	10	0 -0.009	19		29	0 -0.2	22.0	0 -0.2	1.3	18	370	540	4	30
LM12UU	LM12-A	12		21	0 -0.013	30		23.0		1.3	20	410	590	4	31.5
LM13UU	LM13-A	13		23		32		23.0		1.3	22	500	770	4	43
LM16UU	LM16-A	16		28		37		26.5		1.6	27	770	1170	5	69
LM20UU	LM20-A	20		32		42		30.5		1.6	30.5	860	1370	5	87
LM25UU	LM25-A	25	0 -0.010	40	0 -0.016	59		41.0		1.85	38	980	1560	6	220
LM30UU		30		45		64		44.5		1.85	43	1560	2740	6	250
LM35UU		35		52		70	0 -0.3	49.5	0 -0.3	2.1	49	1660	3130	6	390
LM40UU		40	0 -0.012	60	0 -0.019	80		60.5	0 -0.3	2.1	57	2150	4010	6	585
LM50UU		50		80		100		74.0		2.6	76.5	3820	7930	6	1580
LM60UU		60	0 -0.015	90	0 -0.022	110		85.0		3.15	86.5	4700	9990	6	2000
LM80UU		80		120	0 -0.4	140	0 -0.4	105.5	0 -0.4	4.15	116	10130	12000	6	4100

Part Number Notation

LM 20 UU - A N S

- Linear Bushing
- Nominal Shaft Diameter
- Seal

Blank	No Seal
UU	Both Side Seal
U	One Side Seal

Retainer (material)

Blank	Resin Retainer(Standard)
A	Steel Retainer(High temperature) ^{*1}

Outer-sleeves (by corrosion resistance)

Blank	Standard(SUJ2)
N	Electroless nickel plating
R	Raydent treatment

Ball type (material)

Blank	High carbon bearing steel ball(Standard)
S	Stainless steel ball

^{*1} Steel retainer applicable from LM6 to LM25 only (LM8S applicable with resin retainer only)

Drawing

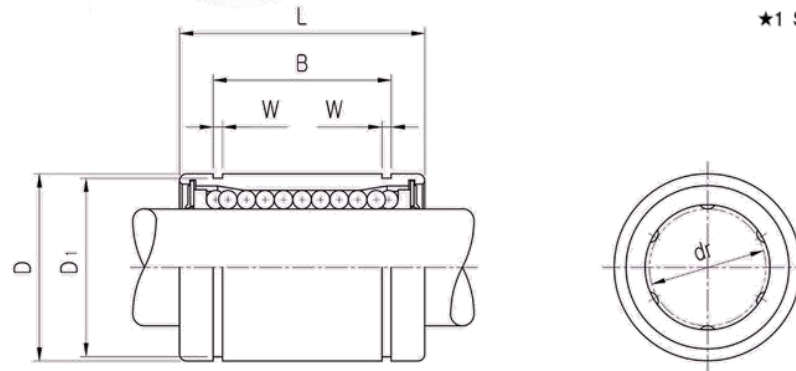

- ^{*1} Dynamic load rating is based on the nominal life of 50km
In case of 100km, C on the table need to be divided by 1.26
Ex) 50km basic dynamic load rating(C) of LM12 = 410N
100km basic dynamic load rating(C₁₀₀) of LM12 = 410/1.26 = 325.40N
- ^{*2} Based on the weight of resin retainer
- ^{*3} Main unit : mm
- ^{*4} 1N ≈ 0.102kgf
- ^{*5} Steel retainer applicable from LM6 to LM25 only (LM8S resin retainer only)

linear bearing LM_L SERIES

Part Number Notation



LM 20 L UU - A N S

- SAMICK Linear Bushing
- Nominal Shaft Diameter
- Linear Bushing Long Type (for high load)
- Seal

Blank	No Seal
UU	Both Side Seal
U	One Side Seal

- Retainer (material)

Blank	Resin Retainer(Standard)
A	Steel Retainer(High temperature) *1

- Outer-sleeves (by corrosion resistance)

Blank	Standard(SUJ2)
N	Electroless nickel plating
R	Raydent treatment

- Ball type (material)

Blank	High carbon bearing steel ball(Standard)
S	Stainless steel ball



● Drawing

*1 Steel retainer applicable from LM6L to LM25L only
(LM8SL applicable with resin retainer only)

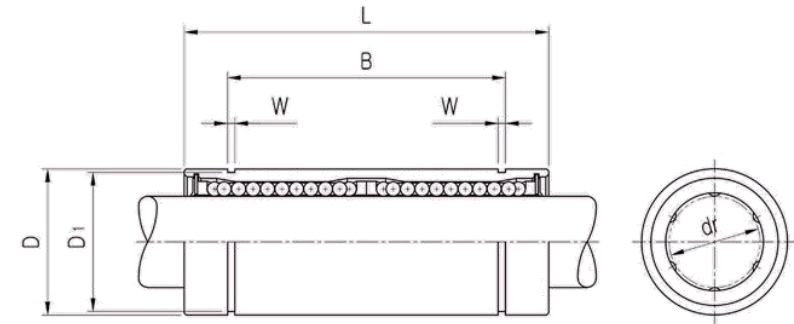

PART NUMBER		WORKING BORE DIAMETER		D		L		B		W	D ₁	BASIC LOAD RATING(N) ^{*4}		NO. OF BALL ROW	WEIGHT (gf) ^{*2}			
Resin	Steel	dr. (mm)	CLEAR NCE(mm)	mm	CLEAR NCE(mm)	mm	CLEAR NCE(mm)	mm	CLEAR NCE(mm)			DYNAMIC (C) ^{*1}	STATIC (Co)					
LM6LUU	LM6L-A	6	0 -0.010	12	0	35	0 -0.3	27	0 -0.3	1.1	11.5	320	520	4	16			
LM8LUU	LM8L-A	8		15	-0.013	45		35		1.1	14.3	430	780	4	31			
LM10LUU	LM10L-A	10		19	55	44		1.3		18	580	1100	4	62				
LM12LUU	LM12L-A	12		21	0	57		-0.3		46	0	-0.3	1.3	20	650	1200	4	80
LM13LUU	LM13L-A	13		23	-0.016	61		46		1.3	22	810	1570	4	90			
LM16LUU	LM16L-A	16		28	70	53		1.6		27	1230	2350	5	145				
LM20LUU	LM20L-A	20		32	80	61		1.6		30.5	1400	2750	5	180				
LM25LUU	LM25L-A	25		0	40	0		-0.019		112	82	1.85	38	1560	3140	6	440	
LM30LUU		30		45	123	89		1.85		43	2490	5490	6	580				
LM35LUU		35		52	135	99		0		0	2.1	49	2650	6470	6	795		
LM40LUU		40	0	60	0	-0.022	154	121	2.1	57	3430	8040	6	1170				
LM50LUU		50	80	192	148	2.6	76.5	6080	15900	6	3100							
LM60LUU		60	0	90	0	-0.025	211	170	3.15	86.5	7650	20000	6	3500				

- *1 Dynamic load rating is based on the nominal life of 50km
In case of 100km, C on the table need to be divided by 1.26
Ex) 50km basic dynamic load rating(C) of LM12L = 650N
100km basic dynamic load rating(C₁₀₀) LM12L = 650/1.26 = 515.87N
- *2 Based on the weight of resin retainer
- *3 Main unit : mm
- *4 1N ≈ 0.102kgf

linear bearing LM_AJ SERIES



PART NUMBER		WORKING BORE DIAMETER		D		L		B		W	h	D ₁	BASIC LOAD RATING(N)		NO. OF BALL ROW	WEIGHT (gf) ^{*2}
Resin	Steel	dr. (mm)	CLEAR NCE (mm)	mm	CLEAR NCE (mm)	mm	CLEAR NCE (mm)	mm	CLEAR NCE (mm)				DYNAMIC (C) ^{*1}	STATIC (Co)		
LM6UU AJ	LM6 AJ-A	6		12		19		13.5		1.1	1	11.5	200	260	4	8
LM8SUU AJ		8		15	0 -0.011	17		11.5		1.1	1	14.3	170	220	4	11
LM8UU AJ	LM8 AJ-A	8		15		24		17.5		1.1	1	14.3	260	400	4	16
LM10UU AJ	LM10 AJ-A	10	0 -0.009	19		29	0 -0.2	22.0	0 -0.2	1.3	1	18	370	540	4	30
LM12UU AJ	LM12 AJ-A	12		21	0 -0.013	30		23.0		1.3	1.5	20	410	590	4	31.5
LM13UU AJ	LM13 AJ-A	13		23		32		23.0		1.3	1.5	22	500	770	4	43
LM16UU AJ	LM16 AJ-A	16		28		37		26.5		1.6	1.5	27	770	1170	5	69
LM20UU AJ	LM20 AJ-A	20		32		42		30.5		1.6	1.5	30.5	860	1370	5	87
LM25UU AJ	LM25 AJ-A	25	0 -0.010	40	0 -0.016	59		41.0		1.85	2	38	980	1560	6	220
LM30UU AJ		30		45		64		44.5		1.85	2.5	43	1560	2740	6	250
LM35UU AJ		35		52		70	0 -0.3	49.5	0 -0.3	2.1	2.5	49	1660	3130	6	390
LM40UU AJ		40	0 -0.012	60	0 -0.019	80		60.5		2.1	3	57	2150	4010	6	585
LM50UU AJ		50		80		100		74.0		2.6	3	76.5	3820	7930	6	1580
LM60UU AJ		60	0 -0.015	90	0 -0.022	110		85.0		3.15	3	86.5	4700	9990	6	2000

LM 20 UU AJ - A N S



● Drawing

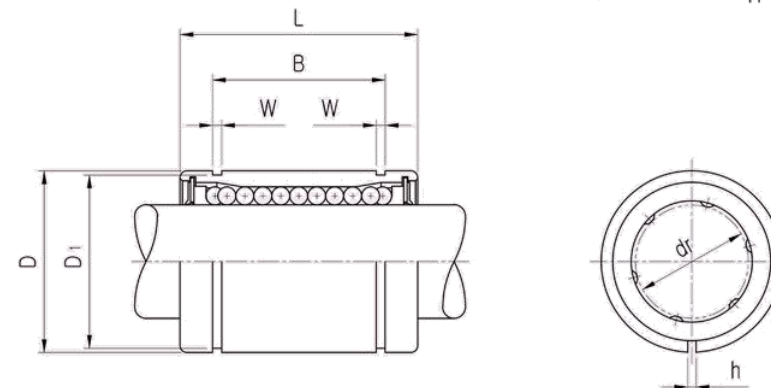

- SAMICK Linear Bushing
- Nominal Shaft Diameter
- Seal

Blank	No Seal
UU	Both Side Seal
U	One Side Seal

- Linear Bushing Adjustable type
- Retainer (material)

Blank	Resin Retainer(Standard)
A	Steel Retainer(High temperature) ^{*1}

- Outer-sleeves (by corrosion resistance)

Blank	Standard(SUU2)
N	Electroless nickel plating
R	Raydent treatment

- Ball type (material)

Blank	High carbon bearing steel ball(Standard)
S	Stainless steel ball

※ ^{*1} Steel retainer applicable from LM6AJ to LM25AJ only

- ★1 Dynamic load rating is based on the nominal life of 50km
In case of 100km, C on the table need to be divided by 1.26
Ex) 50km basic dynamic load rating(C) of LM12AJ = 410N
100km basic dynamic load rating(C₁₀₀) of LM12AJ = 410/1.26 = 325.40N
- ★2 Based on the weight of resin retainer
- ★3 Main unit : mm
- ★4 Outer diameter is the obtained value before the slotting process.
- ★5 1N ≒ 0.102kgf

linear bearing LMF SERIES



Part Number Notation

LMF 20 UU - A N S

PART NUMBER		WORKING BORE DIAMETER		D		L		D ₁		H	PCD	d ₁	d ₂	h	SQUAR ENESS ※(μm)*	BASIC LOAD RATING(N)		NO. OF BALL ROW	WEIGHT (gf)*2
Resin	Steel	dr. (mm)	CLEAR NCE (mm)	mm	CLEAR NCE (mm)	mm	CLEAR NCE (mm)	mm	CLEAR NCE (mm)							DYNAMIC (C)*1	STATIC (Co)		
LMF6UU	LMF6-A	6		12		19		28		5	20	3.4	6.5	3.3	12	220	260	4	26.5
LMF8SUU		8		15	0 -0.011	17		32		5	24	3.4	6.5	3.3	12	170	220	4	34
LMF8UU	LMF8-A	8		15		24		32		5	24	3.4	6.5	3.3	12	260	400	4	40
LMF10UU	LMF10-A	10	0 -0.009	19		29	0 -0.2	40		6	29	4.5	8.0	4.4	12	370	540	4	78
LMF12UU	LMF12-A	12		21	0 -0.013	30		42		6	32	4.5	8.0	4.4	12	410	590	4	76
LMF13UU	LMF13-A	13		23		32		43	0 -0.2	6	33	4.5	8.0	4.4	12	500	770	4	94
LMF16UU	LMF16-A	16		28		37		48		6	38	4.5	8.0	4.4	12	770	1170	5	134
LMF20UU	LMF20-A	20		32		42		54		8	43	5.5	9.5	5.4	15	860	1370	5	180
LMF25UU	LMF25-A	25	0 -0.010	40	0 -0.016	59		62		8	51	5.5	9.5	5.4	15	980	1560	6	340
LMF30UU		30		45		64		74		10	60	6.6	11.0	6.5	15	1560	2740	6	460
LMF35UU		35		52		70		82		10	67	6.6	11.0	6.5	20	1660	3130	6	795
LMF40UU		40	0 -0.012	60	0 -0.019	80	0 -0.3	96		13	78	9.0	14.0	8.6	20	2150	4010	6	1054
LMF50UU		50		80		100		116		13	98	9.0	14.0	8.6	20	3820	7930	6	2200
LMF60UU		60	0 -0.015	90	0 -0.022	110		134	0 -0.3	18	112	11.0	17.5	10.8	25	4700	9990	6	2960
LMF80UU		80		120		140		164		18	142	11.0	17.5	11.1	25	10130	12000	6	5400

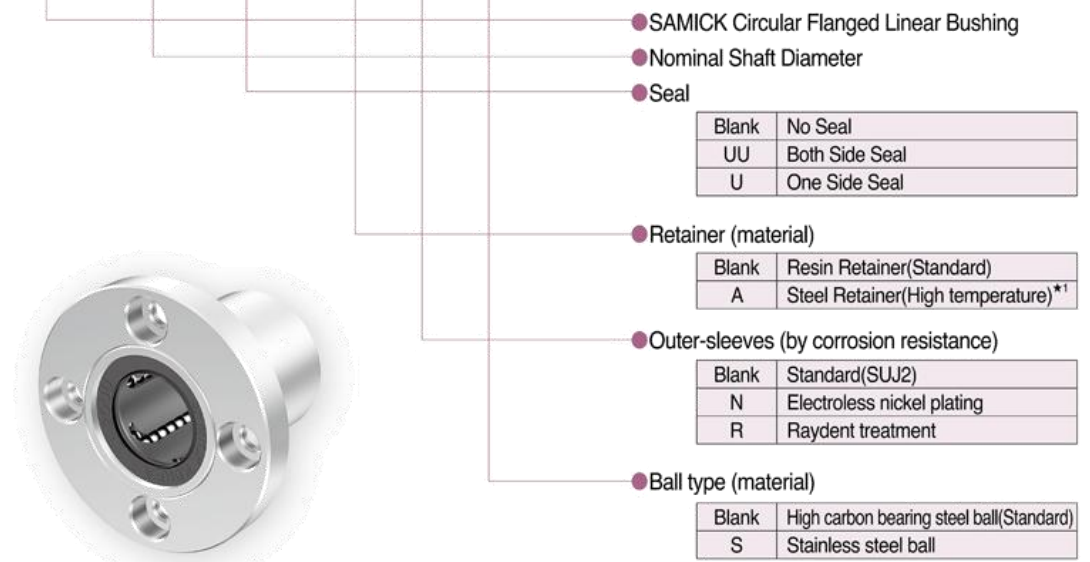

Drawing

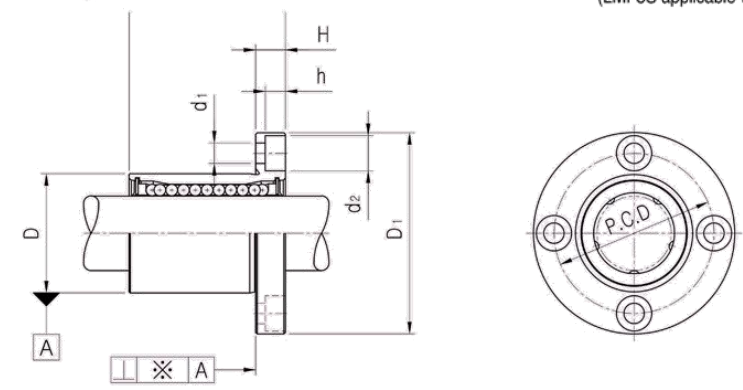

★1 Dynamic load rating is based on the nominal life of 50km
 In case of 100km, C on the table need to be divided by 1.26
 Ex) 50km basic dynamic load rating(C) of LMF12 = 410N
 100km basic dynamic load rating(C₁₀₀) of LMF12 = 410/1.26 = 325.40N

★2 Based on the weight of resin retainer

★3 Main unit : mm

★4 1N ≒ 0.102kgf

linear bearing LMF_L SERIES



PART NUMBER		WORKING BORE DIAMETER		D		L		D ₁		H	PCD	d ₁	d ₂	h	SQUARENESSE ※(μm) [*]	BASIC LOAD RATING(N)		NO. OF BALL ROW	WEIGHT (gf) ^{*2}
Resin	Steel	dr. (mm)	CLEAR NCE (mm)	mm	CLEAR NCE (mm)	mm	CLEAR NCE (mm)	mm	CLEAR NCE (mm)							DYNAMIC (C) ^{*1}	STATIC (Co)		
LMF6LUU	LMF6L-A	6		12	0	35		28		5	20	3.4	6.5	3.3	15	320	520	4	31
LMF8LUU	LMF8L-A	8		15	-0.013	45		32		5	24	3.4	6.5	3.3	15	430	780	4	53
LMF10LUU	LMF10L-A	10	0	19		55		40		6	29	4.5	8.0	4.4	15	580	1100	4	105
LMF12LUU	LMF12L-A	12	-0.010	21	0	57	-0.3	42		6	32	4.5	8.0	4.4	15	650	1200	4	100
LMF13LUU	LMF13L-A	13		23	-0.016	61		43		6	33	4.5	8.0	4.4	15	810	1570	4	130
LMF16LUU	LMF16L-A	16		28		70		48	0	6	38	4.5	8.0	4.4	15	1230	2350	5	187
LMF20LUU	LMF20L-A	20		32		80		54	-0.2	8	43	5.5	9.5	5.4	20	1400	2750	5	260
LMF25LUU	LMF25L-A	25	0	40	0	112	-0.019	62		8	51	5.5	9.5	5.4	20	1560	3140	6	515
LMF30LUU		30		45		123		74		10	60	6.6	11.0	6.5	20	2490	5490	6	655
LMF35LUU		35		52		135		82		10	67	6.6	11.0	6.5	25	2650	6470	6	970
LMF40LUU		40	0	60	0	154	-0.022	96	0	13	78	9.0	14.0	8.6	25	3430	8040	6	1560
LMF50LUU		50		80		192		116	-0.4	13	98	9.0	14.0	8.6	25	6080	15900	6	3500
LMF60LUU		60	0	90	0	211	-0.025	134	0	18	112	11.0	17.5	10.8	30	7650	20000	6	4500

LMF 20 L UU - A N S

- SAMICK Circular Flanged Linear Bushing
- Nominal Shaft Diameter
- Linear Bushing Long Type (for high load)
- Seal

Blank	No Seal
UU	Both Side Seal
U	One Side Seal

- Retainer (material)

Blank	Resin Retainer(Standard)
A	Steel Retainer(High temperature) ^{*1}

- Outer-sleeves (by corrosion resistance)

Blank	Standard(SUJ2)
N	Electroless nickel plating
R	Raydent treatment

- Ball type (material)

Blank	High carbon bearing steel ball(Standard)
S	Stainless steel ball

● Drawing

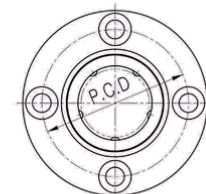
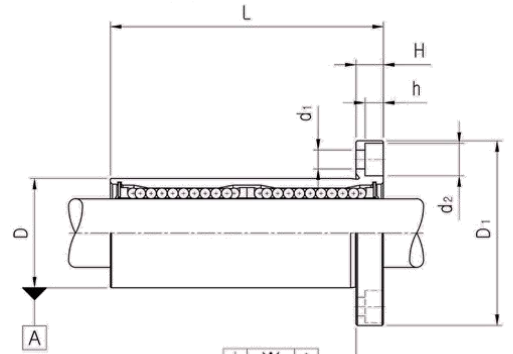

- ★1 Dynamic load rating is based on the nominal life of 50km
In case of 100km, C on the table need to be divided by 1.26
Ex) 50km basic dynamic load rating(C) of LMF12L = 650N
100km basic dynamic load rating(C₁₀₀) of LMF12L = 650/1.26 = 515.87N
- ★2 Based on the weight of resin retainer
- ★3 Main unit : mm
- ★4 1N ≒ 0.102kgf

★1 Steel retainer applicable from LMF6L to LMF25L only

linear bearing LM_OP SERIES



LM 20 UU OP - N S

- SAMICK Linear Bushing
- Nominal Shaft Diameter
- Seal

UU	Both Side Seal *1
----	-------------------
- Linear Bushing Open type
- Outer-sleeves (by corrosion resistance)

Blank	Standard(SUJ2)
N	Electroless nickel plating
R	Raydent treatment
- Ball type (material)

Blank	High carbon bearing steel ball(Standard)
S	Stainless steel ball



● Drawing

- *1 UU type only available.
No seal type & One side seal type not available.
- ★ Resin retainer only applicable

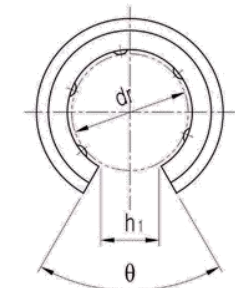
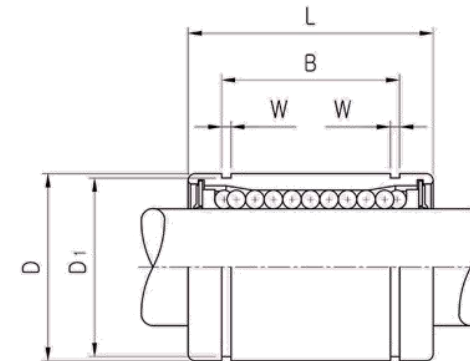

PART NUMBER	WORKING BORE DIAMETER		D**		L		B		W	D ₁	θ	BASIC LOAD RATING(N)		NO. OF BALL ROW	WEIGHT (gf)**2
	Resin	dr. (mm)	CLEAR NCE(mm)	mm	CLEAR NCE(mm)	mm	CLEAR NCE(mm)	mm				CLEAR NCE(mm)	DYNAMIC (C)**1		
LM12UU OP	12		21		30		23.0		1.3	8	80	410	590	3	31.5
LM13UU OP	13	0 -0.009	23	0 -0.013	32	0 -0.2	23.0	0 -0.2	1.3	9	80	500	770	3	43
LM16UU OP	16		28		37		26.5		1.6	11	80	770	1170	4	69
LM20UU OP	20		32		42		30.5		1.6	11	60	860	1370	4	87
LM25UU OP	25	0 -0.010	40	0 -0.016	59		41.0		1.85	12	50	980	1560	5	220
LM30UU OP	30		45		64		44.5		1.85	15	50	1560	2740	5	250
LM35UU OP	35		52		70	0 -0.3	49.5	0 -0.3	2.1	17	50	1660	3130	5	390
LM40UU OP	40	0 -0.012	60	0 -0.019	80		60.5		2.1	20	50	2150	4010	5	585
LM50UU OP	50		80		100		74.0		2.6	25	50	3820	7930	5	1580
LM60UU OP	60	0 -0.015	90	0 -0.022	110		85.0		3.15	30	50	4700	9990	5	2000

★1 Dynamic load rating is based on the nominal life of 50km
 In case of 100km, C on the table need to be divided by 1.26
 Ex) 50km basic dynamic load rating(C) of LM12OP = 410N
 100km basic dynamic load rating(C₁₀₀) of LM12OP = 410/1.26 = 325.40N

★2 Based on the weight of resin retainer

★3 Main unit : mm

★4 Outer diameter is the obtained value before the slotting process.

★5 1N ≈ 0.102kgf

linear bearing LMK SERIES



PART NUMBER		WORKING BORE DIAMETER		D		L		D ₁		H	PCD	K	d ₁	d ₂	h	SQUARENESSE ※(μm)*	BASIC LOAD RATING(N)		NO. OF BALL ROW	WEIGHT (gf)*2
Resin	Steel	dr. (mm)	CLEAR NCE (mm)	mm	CLEAR NCE (mm)	mm	CLEAR NCE (mm)	mm	CLEAR NCE (mm)							DYNAMIC (C)*1	STATIC (Co)			
LMK6UU	LMK6-A	6		12		19		28		5	20	22	3.4	6.5	3.3	12	200	260	4	26.5
LMK8SUU		8		15	0 -0.011	17		32		5	24	25	3.4	6.5	3.3	12	170	220	4	34
LMK8UU	LMK8-A	8		15		24		32		5	24	25	3.4	6.5	3.3	12	260	400	4	40
LMK10UU	LMK10-A	10	0 -0.009	19		29	0 -0.2	40		6	29	30	4.5	8.0	4.4	12	370	540	4	78
LMK12UU	LMK12-A	12		21	0 -0.013	30		42		6	32	32	4.5	8.0	4.4	12	410	590	4	76
LMK13UU	LMK13-A	13		23		32		43	0 -0.2	6	33	34	4.5	8.0	4.4	12	500	770	4	94
LMK16UU	LMK16-A	16		28		37		48		6	38	37	4.5	8.0	4.4	12	770	1170	5	134
LMK20UU	LMK20-A	20		32		42		54		8	43	42	5.5	9.5	5.4	15	860	1370	5	180
LMK25UU	LMK25-A	25	0 -0.010	40	0 -0.016	59		62		8	51	50	5.5	9.5	5.4	15	980	1560	6	340
LMK30UU		30		45		64		74		10	60	58	6.6	11.0	6.5	15	1560	2740	6	460
LMK35UU		35		52		70		82		10	67	64	6.6	11.0	6.5	20	1660	3130	6	795
LMK40UU		40	0 -0.012	60	0 -0.019	80	0 -0.3	96		13	78	75	9.0	14.0	8.6	20	2150	4010	6	1054
LMK50UU		50		80		100		116		13	98	92	9.0	14.0	8.6	20	3820	7930	6	2200
LMK60UU		60	0 -0.015	90	0 -0.022	110		134	0 -0.3	18	112	106	11.0	17.5	10.8	25	4700	9990	6	2960
LMK80UU		80		120		140		164		18	142	136	11.0	17.5	11.1	25	10130	12000	6	4900

Part Number Notation

LMK 20 UU - A N S

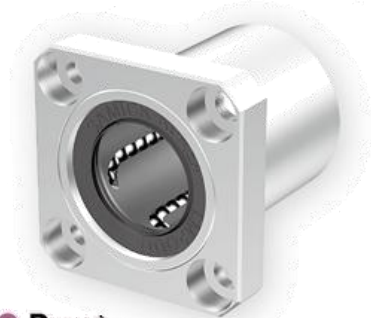

- SAMICK Square Flanged Linear Bushing
- Nominal Shaft Diameter
- Seal

Blank	No Seal
UU	Both Side Seal
U	One Side Seal

- Retainer (material)

Blank	Resin Retainer(Standard)
A	Steel Retainer(High temperature)*1

- Outer-sleeves (by corrosion resistance)

Blank	Standard(SUJ2)
N	Electroless nickel plating
R	Raydent treatment

- Ball type (material)

Blank	High carbon bearing steel ball(Standard)
S	Stainless steel ball

*1 Steel retainer applicable from LMK6 to LMK25 only (LMK8S applicable with resin retainer only)

Drawing

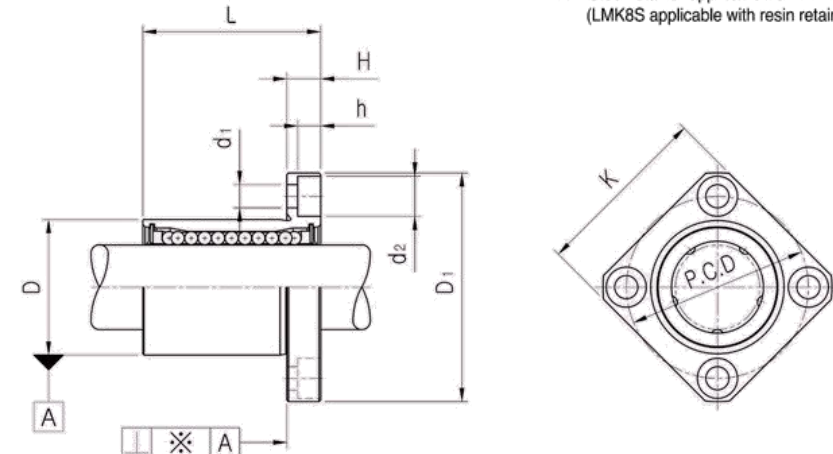

- ★1 Dynamic load rating is based on the nominal life of 50km
In case of 100km, C on the table need to be divided by 1.26
Ex) 50km basic dynamic load rating(C) of LMK12 = 410N
100km basic dynamic load rating(C₁₀₀) of LMK12 = 410/1.26 = 325.40N
- ★2 Based on the weight of resin retainer
- ★3 Main unit : mm
- ★4 1N ≒ 0.102kgf

linear bearing LMK_L SERIES



PART NUMBER		WORKING BORE DIAMETER		D		L		D ₁		H	PCD	K	d ₁	d ₂	h	SQUARENESSE ※(μm)*	BASIC LOAD RATING(N)		NO. OF BALL ROW	WEIGHT (gf) ^{†2}
Resin	Steel	dr. (mm)	CLEAR NCE (mm)	mm	CLEAR NCE (mm)	mm	CLEAR NCE (mm)	mm	CLEAR NCE (mm)								DYNAMIC (C) ^{†1}	STATIC (Co)		
LMK6LUU	LMK6L-A	6		12	0	35		28		5	20	22	3.4	6.5	3.3	15	320	520	4	31
LMK8LUU	LMK8L-A	8		15	-0.013	45		32		5	24	25	3.4	6.5	3.3	15	430	780	4	53
LMK10LUU	LMK10L-A	10	0	19		55	0	40		6	29	30	4.5	8.0	4.4	15	580	1100	4	105
LMK12LUU	LMK12L-A	12	-0.010	21	0	57	-0.3	42		6	32	32	4.5	8.0	4.4	15	650	1200	4	100
LMK13LUU	LMK13L-A	13		23	-0.016	61		43		6	33	34	4.5	8.0	4.4	15	810	1570	4	130
LMK16LUU	LMK16L-A	16		28		70		48	0	6	38	37	4.5	8.0	4.4	15	1230	2350	5	187
LMK20LUU	LMK20L-A	20		32		80		54	-0.2	8	43	42	5.5	9.5	5.4	20	1400	2750	5	260
LMK25LUU	LMK25L-A	25	0	40	0	112		62		8	51	50	5.5	9.5	5.4	20	1560	3140	6	515
LMK30LUU		30	-0.012	45	-0.019	123		74		10	60	58	6.6	11.0	6.5	20	2490	5490	6	655
LMK35LUU		35		52		135	0	82		10	67	64	6.6	11.0	6.5	25	2650	6470	6	970
LMK40LUU		40	0	60	0	154	-0.4	96		13	78	75	9.0	14.0	8.6	25	3430	8040	6	1560
LMK50LUU		50	-0.015	80	-0.022	192		116	0	13	98	92	9.0	14.0	8.6	25	6080	15900	6	3500
LMK60LUU		60	0	90	0	211	-0.3	134		18	112	106	11.0	17.5	10.8	30	7650	20000	6	4500

LMK 20 L UU - A N S



● Drawing

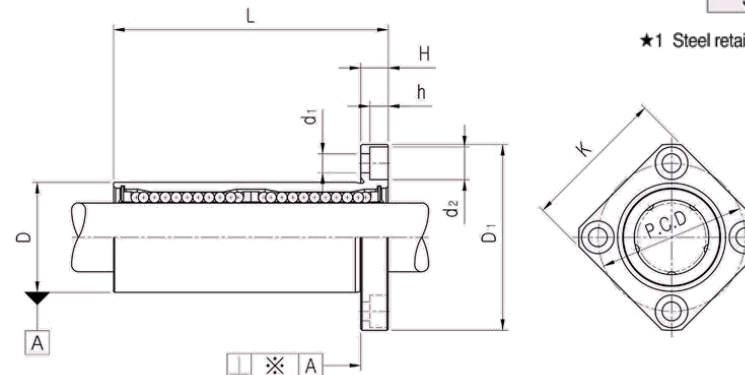

- SAMICK Square Linear Bushing
- Nominal Shaft Diameter
- Linear Bushing Long Type (for high load)
- Seal

Blank	No Seal
UU	Both Side Seal
U	One Side Seal

● Retainer (material)

Blank	Resin Retainer(Standard)
A	Steel Retainer(High temperature) *1

● Outer-sleeves (by corrosion resistance)

Blank	Standard(SUJ2)
N	Electroless nickel plating
R	Raydent treatment

● Ball type (material)

Blank	High carbon bearing steel ball(Standard)
S	Stainless steel ball

*1 Steel retainer applicable from LMK6L to LMK25L only

- ★1 Dynamic load rating is based on the nominal life of 50km
In case of 100km, C on the table need to be divided by 1.26
Ex) 50km basic dynamic load rating(C) of LMK12L = 650N
100km basic dynamic load rating(C₁₀₀) of LMK12L = 650/1.26 = 515.87N
- ★2 Based on the weight of resin retainer
- ★3 Main unit : mm
- ★4 1N ≒ 0.102kgf

linear bearing LMH SERIES



● Part Number Notation

LMH 20 UU - A N S

- SAMICK Oval Flanged Linear Bushing
- Nominal Shaft Diameter
- Seal

Blank	No Seal
UU	Both Side Seal
U	One Side Seal

- Retainer (material)

Blank	Resin Retainer(Standard)
A	Steel Retainer(High temperature) ^{★1}

- Outer-sleeves (by corrosion resistance)

Blank	Standard(SUJ2)
N	Electroless nickel plating
R	Raydent treatment

- Ball type (material)

Blank	High carbon bearing steel ball(Standard)
S	Stainless steel ball



● Drawing

★1 Steel retainer applicable from LMH6 to LMH25 only

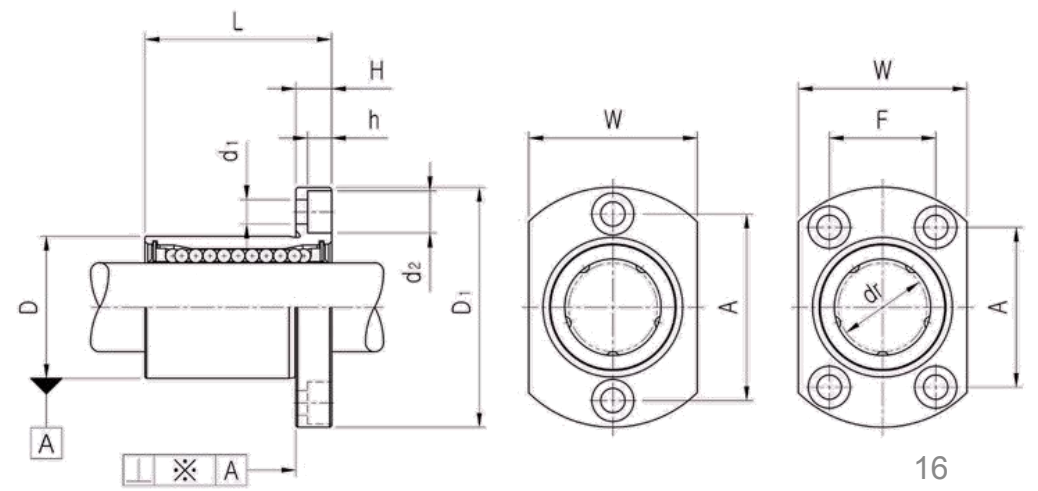

PART NUMBER		WORKING BORE DIAMETER		D		L		D ₁		H	W	A	F	d ₁	d ₂	h	SQUAR ENESS ※(μm) [★]	BASIC LOAD RATING(N)		NO. OF BALL ROW	WEIGHT (gf) ^{★2}
Resin	Steel	dr. (mm)	CLEAR NCE (mm)	mm	CLEAR NCE (mm)	mm	CLEAR NCE (mm)	mm	CLEAR NCE (mm)	DYNAMIC (C) ^{★1}	STATIC (Co)										
LMH6UU	LMH6-A	6		12	0	19		28		5	18	20	-	3.4	6.5	3.3	12	200	260	4	26.5
LMH8UU	LMH8-A	8		15	-0.011	24		32		5	21	24	-	3.4	6.5	3.3	12	260	400	4	40
LMH10UU	LMH10-A	10	0	19		29		40		6	25	29	-	4.5	8.0	4.4	12	370	540	4	78
LMH12UU	LMH12-A	12	-0.09	21	0	30	0	42		6	27	32	-	4.5	8.0	4.4	12	410	590	4	76
LMH13UU	LMH13-A	13		23	-0.013	32		43	0	6	29	33	-	4.5	8.0	4.4	12	500	770	4	94
LMH16UU	LMH16-A	16		28		37		48	-0.2	6	34	31	22	4.5	8.0	4.4	12	770	1170	5	134
LMH20UU	LMH20-A	20		32		42		54		8	38	36	24	5.5	9.5	5.4	15	860	1370	5	180
LMH25UU	LMH25-A	25	0	40	0	59	0	62		8	46	40	32	5.5	9.5	5.4	15	980	1560	6	340
LMH30UU		30	-0.010	45	-0.016	64	0	74	-0.3	10	51	49	35	6.6	11.0	6.5	15	1560	2740	6	460

- ★1 Dynamic load rating is based on the nominal life of 50km
In case of 100km, C on the table need to be divided by 1.26
Ex) 50km basic dynamic load rating(C) of LMH12 = 410N
100km basic dynamic load rating(C₁₀₀) of LMH12 = 410/1.26 = 325.40N
- ★2 Based on the weight of resin retainer
- ★3 Main unit : mm
- ★4 1N ≒ 0.102kgf

linear bearing LMH_L SERIES



LMH 20 L UU - A N S

PART NUMBER		WORKING BORE DIAMETER		D		L		D ₁		H	W	A	F	d ₁	d ₂	h	SQUARENESSE ※(μm)*	BASIC LOAD RATING(N)		NO. OF BALL ROW	WEIGHT (gf) ^{**2}
Resin	Steel	dr. (mm)	CLEAR NCE (mm)	mm	CLEAR NCE (mm)	mm	CLEAR NCE (mm)	mm	CLEAR NCE (mm)	DYNAMIC (C) ^{**1}	STATIC (Co)										
LMH6LUU	LMH6L-A	6		12	0	35		28		5	18	20	-	3.4	6.5	3.3	15	320	520	4	31
LMH8LUU	LMH8L-A	8		15	-0.013	45		32		5	21	24	-	3.4	6.5	3.3	15	430	780	4	53
LMH10LUU	LMH10L-A	10	0 -0.010	19		55		40		6	25	29	-	4.5	8.0	4.4	15	580	1100	4	105
LMH12LUU	LMH12L-A	12		21	0	57	-0.3	42		6	27	32	-	4.5	8.0	4.4	15	650	1200	4	100
LMH13LUU	LMH13L-A	13		23	-0.016	61		43	0 -0.2	6	29	33	-	4.5	8.0	4.4	15	810	1570	4	130
LMH16LUU	LMH16L-A	16		28		70		48		6	34	31	22	4.5	8.0	4.4	15	1230	2350	5	187
LMH20LUU	LMH20L-A	20		32		80		54		8	38	36	24	5.5	9.5	5.4	20	1400	2750	5	260
LMH25LUU	LMH25L-A	25	0 -0.012	40	0 -0.019	112	0 -0.4	62		8	46	40	32	5.5	9.5	5.4	20	1560	3140	6	515
LMH30LUU		30		45		123		74		10	51	49	35	6.6	11.0	6.5	20	2490	5490	6	655

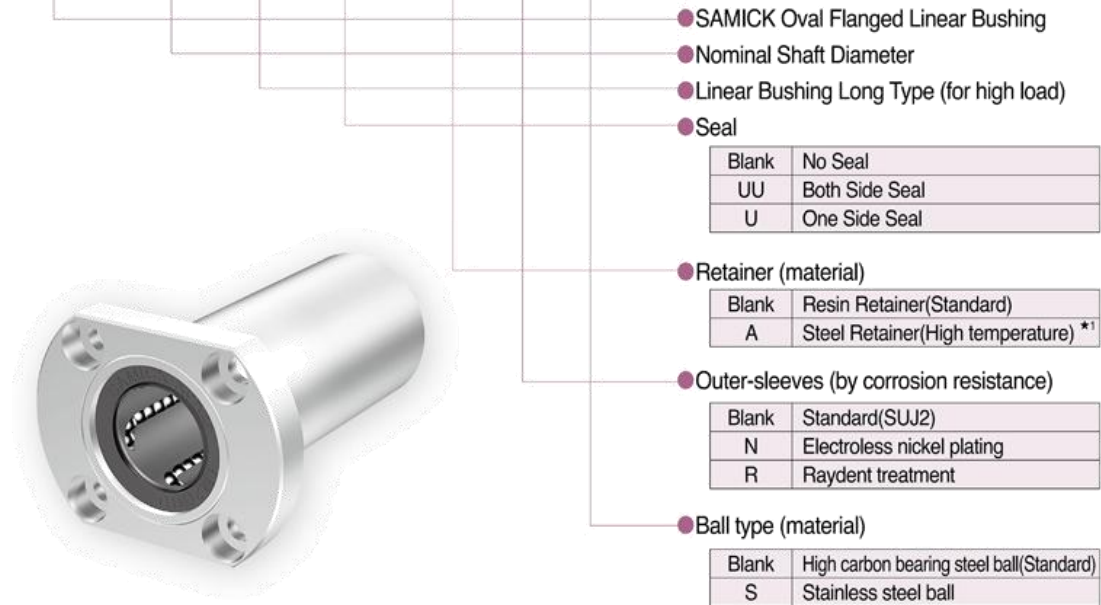

● Drawing

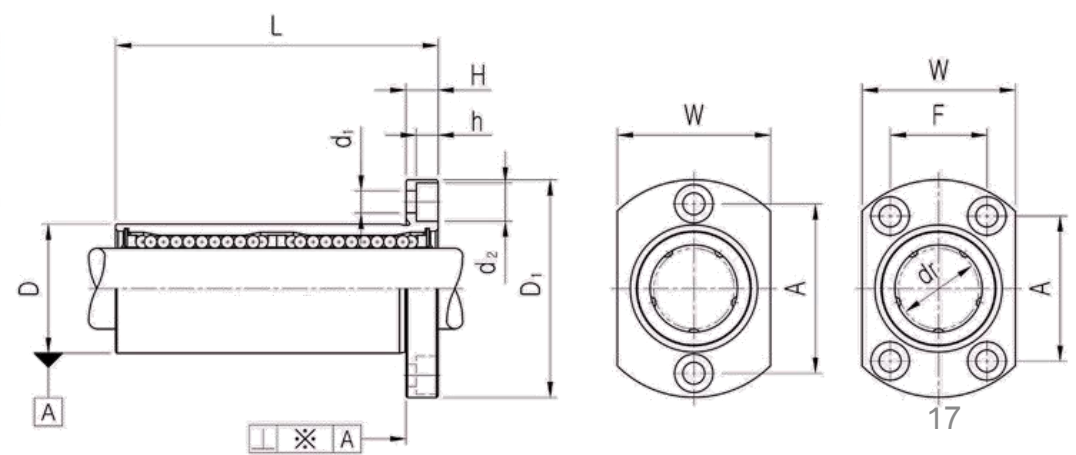

★1 Dynamic load rating is based on the nominal life of 50km
 In case of 100km, C on the table need to be divided by 1.26
 Ex) 50km basic dynamic load rating(C) of LMH12L = 650N
 100km basic dynamic load rating(C₁₀₀) of LMH12L = 650/1.26 = 515.87N

★2 Based on the weight of resin retainer

★3 Main unit : mm

★4 1N ≒ 0.102kgf

★1 Steel retainer applicable from LMH6L to LMH25L only

linear bearing LMFP SERIES



LMFP 20 UU - A N S

PART NUMBER		WORKING BORE DIAMETER		D		L		D ₁		ℓ	H	PCD	d ₁	d ₂	h	SQUARENNESS ※(μm) [†]	BASIC LOAD RATING(N)		NO. OF BALL ROW	WEIGHT (gf) ^{*2}
Resin	Steel	dr. (mm)	CLEAR NCE (mm)	mm	CLEAR NCE (mm)	mm	CLEAR NCE (mm)	mm	CLEAR NCE (mm)							DYNAMIC (C) ^{*1}	STATIC (Co)			
LMFP6UU	LMFP6-A	6		12	0	19		28		5	5	20	3.4	6.5	3.3	12	200	260	4	26.5
LMFP8UU	LMFP8-A	8		15	-0.011	24		32		5	5	24	3.4	6.5	3.3	12	260	400	4	40
LMFP10UU	LMFP10-A	10	0	19		29		40		6	6	29	4.5	8	4.4	12	370	540	4	76
LMFP12UU	LMFP12-A	12	-0.009	21	0	30	0	42	0	6	6	32	4.5	8	4.4	12	410	590	4	78
LMFP13UU	LMFP13-A	13		23	-0.013	32		43		6	6	33	4.5	8	4.4	12	500	770	4	94
LMFP16UU	LMFP16-A	16		28		37		48	0	6	6	38	4.5	8	4.4	12	770	1170	5	134
LMFP20UU	LMFP20-A	20		32		42		54	-0.2	8	8	43	5.5	9.5	5.4	15	860	1370	5	180
LMFP25UU	LMFP25-A	25	0	40	0	59		62		8	8	51	5.5	9.5	5.4	15	980	1560	6	340
LMFP30UU		30		45		64		74		10	10	60	6.6	11	6.5	15	1560	2740	6	460
LMFP35UU		35		52		70		82		10	10	67	6.6	11	6.5	20	1660	3130	6	795
LMFP40UU		40	0	60	0	80	0	96	-0.3	13	13	78	9	14	8.6	20	2150	4010	6	1054
LMFP50UU		50	-0.012	80	0	100		116	0	13	13	98	9	14	8.6	20	3820	7930	6	2200
LMFP60UU		60	0	90	0	110		134	-0.3	18	18	112	11	17.5	10.8	25	4700	9990	6	2960

- SAMICK Circular Pilot Flanged Linear Bushing
- Nominal Shaft Diameter
- Seal

Blank	No Seal
UU	Both Side Seal
U	One Side Seal

- Retainer (material)

Blank	Resin Retainer(Standard)
A	Steel Retainer(High temperature) ^{*1}

- Outer-sleeves (by corrosion resistance)

Blank	Standard(SUJ2)
N	Electroless nickel plating
R	Raydent treatment

- Ball type (material)

Blank	High carbon bearing steel ball(Standard)
S	Stainless steel ball

● Drawing

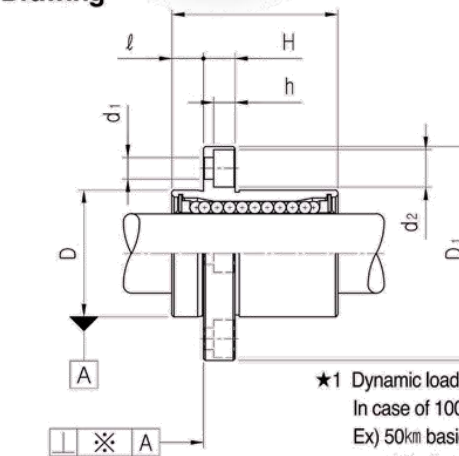

★1 Steel retainer applicable from LMFP6 to LMFP25 only

★1 Dynamic load rating is based on the nominal life of 50km
 In case of 100km, C on the table need to be divided by 1.26
 Ex) 50km basic dynamic load rating(C) of LMFP12 = 410N
 100km basic dynamic load rating(C₁₀₀) of LMFP12 = 410/1.26 = 325.40N

★2 Based on the weight of resin retainer

★3 Main unit : mm

★4 1N ≒ 0.102kgf

linear bearing LMFP_L SERIES



PART NUMBER		WORKING BORE DIAMETER		D		L		D ₁		ℓ	H	PCD	d ₁	d ₂	h	SQUARENESSE ※(μm)*	BASIC LOAD RATING(N)		NO. OF BALL ROW	WEIGHT (gf)*2
Resin	Steel	dr. (mm)	CLEAR NCE (mm)	mm	CLEAR NCE (mm)	mm	CLEAR NCE (mm)	mm	CLEAR NCE (mm)								DYNAMIC (C)*1	STATIC (Co)		
LMFP6LUU	LMFP6L-A	6		12	0	35		28		5	5	20	3.4	6.5	3.3	15	320	520	4	31
LMFP8LUU	LMFP8L-A	8		15	-0.013	45		32		5	5	24	3.4	6.5	3.3	15	430	780	4	53
LMFP10LUU	LMFP10L-A	10	0	19		55		40		6	6	29	4.5	8	4.4	15	580	1100	4	105
LMFP12LUU	LMFP12L-A	12	-0.010	21	0	57	0	42		6	6	32	4.5	8	4.4	15	650	1200	4	100
LMFP13LUU	LMFP13L-A	13		23	-0.016	61		43		6	6	33	4.5	8	4.4	15	810	1570	4	130
LMFP16LUU	LMFP16L-A	16		28		70		48	0	6	6	38	4.5	8	4.4	15	1230	2350	5	187
LMFP20LUU	LMFP20L-A	20		32		80		54	-0.2	8	8	43	5.5	9.5	5.4	20	1400	2750	5	260
LMFP25LUU	LMFP25L-A	25	0	40	0	112		62		8	8	51	5.5	9.5	5.4	20	1560	3140	6	515
LMFP30LUU		30	-0.012	45	-0.019	123		74		10	10	60	6.6	11	6.5	20	2490	5490	6	655
LMFP35LUU		35		52		135		82		10	10	67	6.6	11	6.5	25	2650	6470	6	970
LMFP40LUU		40	0	60	0	154	0	96	-0.4	13	13	78	9	14	8.6	25	3430	8040	6	1560
LMFP50LUU		50	-0.015	80	-0.022	192		116		13	13	98	9	14	8.6	25	6080	15900	6	3500
LMFP60LUU		60	0	90	0	211		134	0	18	18	112	11	17.5	10.8	30	7650	20000	6	4500
			-0.020		-0.025															

LMFP 20 L UU - A N S



- SAMICK Circular Flanged Linear Bushing
- Nominal Shaft Diameter
- Linear Bushing Long Type (for high load)
- Seal

Blank	No Seal
UU	Both Side Seal
U	One Side Seal

- Retainer (material)

Blank	Resin Retainer(Standard)
A	Steel Retainer(High temperature)*1

- Outer-sleeves (by corrosion resistance)

Blank	Standard(SUJ2)
N	Electroless nickel plating
R	Raydent treatment

- Ball type (material)

Blank	High carbon bearing steel ball(Standard)
S	Stainless steel ball

★1 Steel retainer applicable from LMFP6L to LMFP25L only

● Drawing

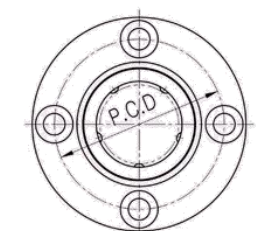
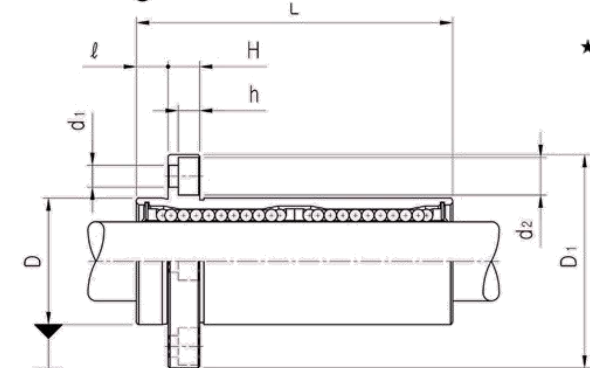

★1 Dynamic load rating is based on the nominal life of 50km
 In case of 100km, C on the table need to be divided by 1.26
 Ex) 50km basic dynamic load rating(C) of LMFP12L = 650N
 100km basic dynamic load rating(C₁₀₀) of LMFP12L = 650/1.26 = 515.87N

- ★2 Based on the weight of resin retainer
- ★3 Main unit : mm
- ★4 1N ≒ 0.102kgf

linear bearing LMKP SERIES



PART NUMBER		WORKING BORE DIAMETER		D		L		D ₁		ℓ	H	PCD	K	d ₁	d ₂	h	SQUAR ENESS ※(μ) [*]	BASIC LOAD RATING(N)		NO. OF BALL ROW	WEIGHT (gf) ^{*2}
Resin	Steel	dr. (mm)	CLEAR NCE (mm)	mm	CLEAR NCE (mm)	mm	CLEAR NCE (mm)	mm	CLEAR NCE (mm)									DYNAMIC (C) ^{*1}	STATIC (Co)		
LMKP6UU	LMKP6-A	6		12	0	19		28		5	5	20	22	3.4	6.5	3.3	12	200	260	4	26.5
LMKP8UU	LMKP8-A	8		15	-0.011	24		32		5	5	24	25	3.4	6.5	3.3	12	260	400	4	40
LMKP10UU	LMKP10-A	10	0	19		29		40		6	6	29	30	4.5	8	4.4	12	370	540	4	76
LMKP12UU	LMKP12-A	12	-0.009	21	0	30	0	42	-0.2	6	6	32	32	4.5	8	4.4	12	410	590	4	78
LMKP13UU	LMKP13-A	13		23	-0.013	32		43		6	6	33	34	4.5	8	4.4	12	500	770	4	94
LMKP16UU	LMKP16-A	16		28		37		48	0	6	6	38	37	4.5	8	4.4	12	770	1170	5	134
LMKP20UU	LMKP20-A	20		32		42		54		8	8	43	42	5.5	9.5	5.4	15	860	1370	5	180
LMKP25UU	LMKP25-A	25	0	40	0	59		62		8	8	51	50	5.5	9.5	5.4	15	980	1560	6	340
LMKP30UU		30		45		64		74		10	10	60	58	6.6	11	6.5	15	1560	2740	6	460
LMKP35UU		35		52		70		82		10	10	67	64	6.6	11	6.5	20	1660	3130	6	795
LMKP40UU		40	0	60	0	80	0	96	-0.3	13	13	78	75	9	14	8.6	20	2150	4010	6	1054
LMKP50UU		50		80		100		116	0	13	13	98	92	9	14	8.6	20	3820	7930	6	2200
LMKP60UU		60	0	90	0	110		134	-0.3	18	18	112	106	11	17.5	10.8	25	4700	9990	6	2960

LMKP 20 UU - A N S

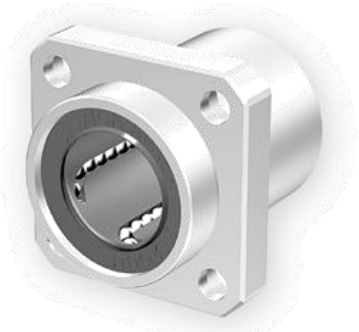

● Drawing

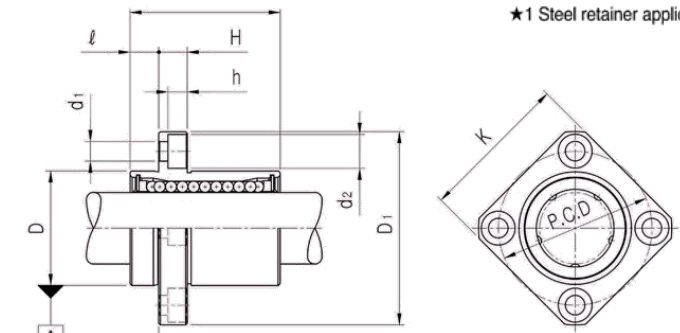

- SAMICK Square Pilot Flanged Linear Bushing
- Nominal Shaft Diameter
- Seal

Blank	No Seal
UU	Both Side Seal
U	One Side Seal

- Retainer (material)

Blank	Resin Retainer(Standard)
A	Steel Retainer(High temperature) ^{*1}

- Outer-sleeves (by corrosion resistance)

Blank	Standard(SUJ2)
N	Electroless nickel plating
R	Raydent treatment

- Ball type (material)

Blank	High carbon bearing steel ball(Standard)
S	Stainless steel ball

★1 Steel retainer applicable from LMKP6 to LMKP25 only

★1 Dynamic load rating is based on the nominal life of 50km
 In case of 100km, C on the table need to be divided by 1.26
 Ex) 50km basic dynamic load rating(C) of LMKP12 = 410N
 100km basic dynamic load rating(C₁₀₀) of LMKP12 = 410/1.26 = 325.40N

- ★2 Based on the weight of resin retainer
- ★3 Main unit : mm
- ★4 1N ≒ 0.102kgf

linear bearing LMKP_L SERIES



PART NUMBER		WORKING BORE DIAMETER		D		L		D ₁		ℓ	H	PCD	K	d ₁	d ₂	h	SQUARENESSE ※(μm)*	BASIC LOAD RATING(N)		NO. OF BALL ROW	WEIGHT (g) ^{※2}		
Resin	Steel	dr. (mm)	CLEAR NCE (mm)	CLEAR NCE (mm)	CLEAR NCE (mm)	CLEAR NCE (mm)	CLEAR NCE (mm)	DYNAMIC (C) ^{※1}	STATIC (Co)														
LMKP6LUU	LMKP6L-A	6	0	12	0	35	0	28	-0.2	5	5	20	22	3.4	6.5	3.3	15	320	520	4	31		
LMKP8LUU	LMKP8L-A	8		15	-0.013	45		32		5	5	24	25	3.4	6.5	3.3	15	430	780	4	53		
LMKP10LUU	LMKP10L-A	10		19	-0.010	55		40		6	6	29	30	4.5	8	4.4	15	580	1100	4	105		
LMKP12LUU	LMKP12L-A	12		21		0		57		-0.3	42	6	6	32	32	4.5	8	4.4	15	650	1200	4	100
LMKP13LUU	LMKP13L-A	13		23		-0.016		61		43	6	6	33	34	4.5	8	4.4	15	810	1570	4	130	
LMKP16LUU	LMKP16L-A	16		28		70		48		6	6	38	37	4.5	8	4.4	15	1230	2350	5	187		
LMKP20LUU	LMKP20L-A	20	32	80		54	8	8	43	42	5.5	9.5	5.4	20	1400	2750	5	260					
LMKP25LUU	LMKP25L-A	25	0	40		0	112	62	8	8	51	50	5.5	9.5	5.4	20	1560	3140	6	515			
LMKP30LUU		30	45	123	74	10	10	60	58	6.6	11	6.5	20	2490	5490	6	655						
LMKP35LUU		35	52	135	82	10	10	67	64	6.6	11	6.5	25	2650	6470	6	970						
LMKP40LUU		40	0	60	0	154	96	13	13	78	75	9	14	8.6	25	3430	8040	6	1560				
LMKP50LUU		50	-0.015	80	-0.022	192	116	13	13	98	92	9	14	8.6	25	6080	15900	6	3500				
LMKP60LUU		60	0	90	0	211	134	18	18	112	106	11	17.5	10.8	30	7650	20000	6	4500				

LMKP 20 L UU - A N S



- SAMICK Square Flanged Linear Bushing
- Nominal Shaft Diameter
- Linear Bushing Long Type (for high load)
- Seal

Blank	No Seal
UU	Both Side Seal
U	One Side Seal

- Retainer (material)

Blank	Resin Retainer(Standard)
A	Steel Retainer(High temperature) *1

- Outer-sleeves (by corrosion resistance)

Blank	Standard(SUJ2)
N	Electroless nickel plating
R	Raydent treatment

- Ball type (material)

Blank	High carbon bearing steel ball(Standard)
S	Stainless steel ball

● Drawing

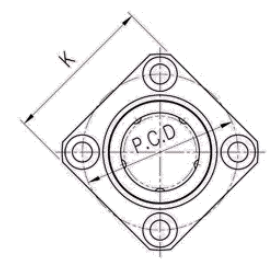
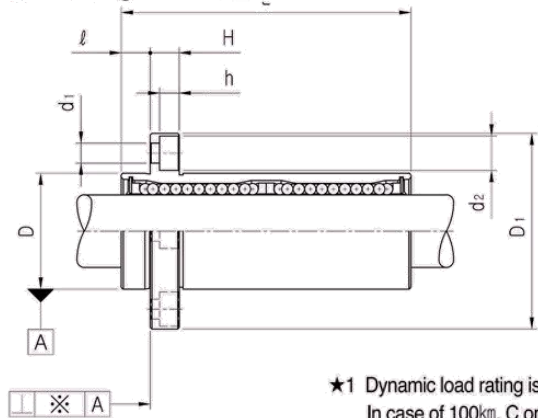

★1 Steel retainer applicable from LMKP6L to LMKP25L only

- ★1 Dynamic load rating is based on the nominal life of 50km
In case of 100km, C on the table need to be divided by 1.26
Ex) 50km basic dynamic load rating(C) of LMKP12L = 650N
100km basic dynamic load rating(C₁₀₀) of LMKP12L = 650/1.26 = 515.87N
- ★2 Based on the weight of resin retainer
- ★3 Main unit : mm
- ★4 1N ≒ 0.102kgf

linear bearing LMHP SERIES



LMHP 20 UU - A N S

PART NUMBER		WORKING BORE DIAMETER		D		L		D ₁		ℓ	H	W	A	F	d ₁	d ₂	h	SQUARENESSE ※(μm)*	BASIC LOAD RATING(N)		NO. OF BALL ROW	WEIGHT (gf)*2
Resin	Steel	dr. (mm)	CLEAR NCE (mm)	CLEAR NCE (mm)	CLEAR NCE (mm)	CLEAR NCE (mm)	DYNAMIC (C)*1	STATIC (Co)														
LMHP6UU	LMHP6-A	6	0	12	0	19	0	28	0	5	5	18	20	3.4	6.5	3.3	12	200	260	4	26.5	
LMHP8UU	LMHP8-A	8		-0.011	24	32		5		5	21	24	3.4					6.5	3.3	12	260	400
LMHP10UU	LMHP10-A	10	0	19	0	29	0	40	0	6	6	25	29	4.5	8	4.4	12	370	540	4	76	
LMHP12UU	LMHP12-A	12		-0.009		21		0		30	-0.2	42	6					6	27	32	4.5	8
LMHP13UU	LMHP13-A	13	0	23	0	32	0	43	0	6	6	29	33	4.5	8	4.4	12	500	770	4	94	
LMHP16UU	LMHP16-A	16		-0.013		37		48		6	6	34	31					22	4.5	8	4.4	12
LMHP20UU	LMHP20-A	20	0	32	0	42	0	54	0	8	8	38	36	24	5.5	9.5	5.4	15	860	1370	5	180
LMHP25UU	LMHP25-A	25		-0.010		40		0		59	0	62	8	8	46	40	32	5.5	9.5	5.4	15	980
LMHP30UU		30	0	45	0	64	0	74	0	10	10	51	49	35	6.6	11	6.5	15	1560	2740	6	460

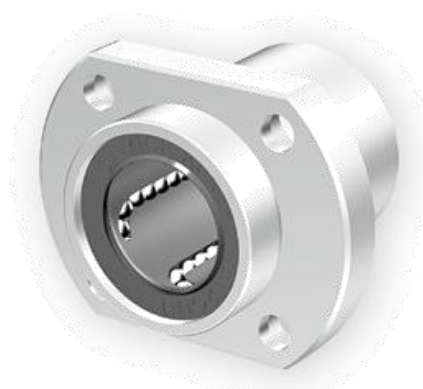

- SAMICK Oval Pilot Flanged Linear Bushing
- Nominal Shaft Diameter
- Seal

Blank	No Seal
UU	Both Side Seal
U	One Side Seal

- Retainer (material)

Blank	Resin Retainer(Standard)
A	Steel Retainer(High temperature)*1

- Outer-sleeves (by corrosion resistance)

Blank	Standard(SUJ2)
N	Electroless nickel plating
R	Raydent treatment

- Ball type (material)

Blank	High carbon bearing steel ball(Standard)
S	Stainless steel ball

● Drawing

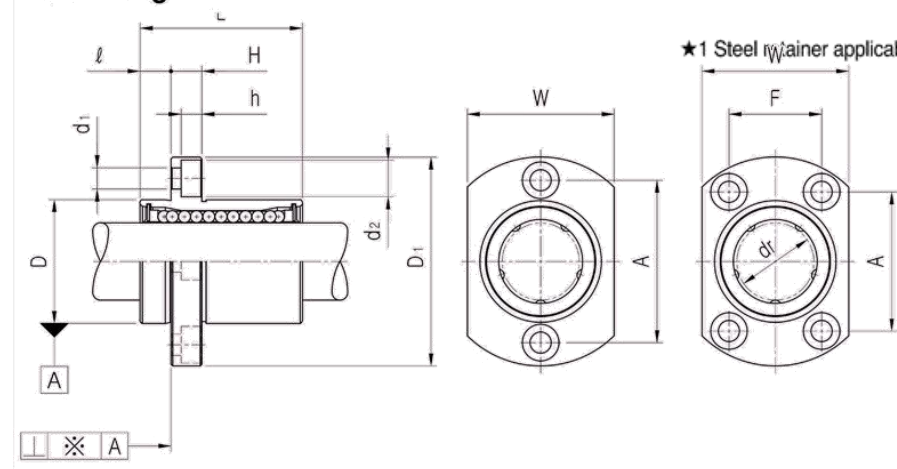

- ★1 Dynamic load rating is based on the nominal life of 50km
In case of 100km, C on the table need to be divided by 1.26
Ex) 50km basic dynamic load rating(C) of LMHP12 = 410N
100km basic dynamic load rating(C₁₀₀) of LMHP12 = 410/1.26 = 325.40N
- ★2 Based on the weight of resin retainer
- ★3 Main unit : mm
- ★4 1N ≒ 0.102kgf

linear bearing LMHP_L SERIES



LMHP 20 L UU - A N S

- SAMICK Oval Flanged Linear Bushing
- Nominal Shaft Diameter
- Linear Bushing Long Type (for high load)
- Seal

Blank	No Seal
UU	Both Side Seal
U	One Side Seal
- Retainer (material)

Blank	Resin Retainer(Standard)
A	Steel Retainer(High temperature) *1
- Outer-sleeves (by corrosion resistance)

Blank	Standard(SUJ2)
N	Electroless nickel plating
R	Raydent treatment
- Ball type (material)

Blank	High carbon bearing steel ball(Standard)
S	Stainless steel ball



● Drawing

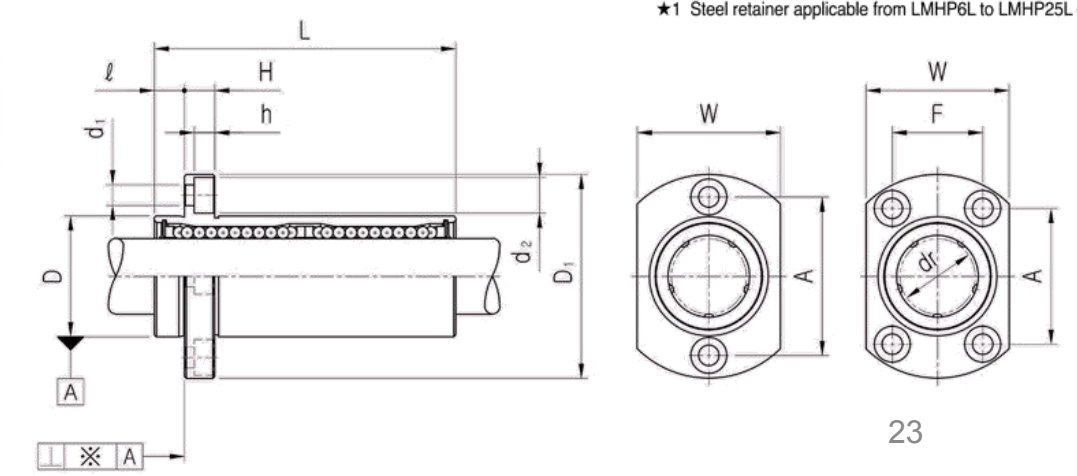

★1 Steel retainer applicable from LMHP6L to LMHP25L only

PART NUMBER		WORKING BORE DIAMETER		D		L		D ₁		ℓ	H	W	A	F	d ₁	d ₂	h	SQUARENESSE ※(μm)*	BASIC LOAD RATING(N)		NO. OF BALL ROW	WEIGHT (gf) ^{*2}
Resin	Steel	dr. (mm)	CLEAR NCE (mm)	mm	CLEAR NCE (mm)	mm	CLEAR NCE (mm)	mm	CLEAR NCE (mm)	DYNAMIC (C) ^{*1}	STATIC (Co)											
LMHP6LUU	LMHP6L-A	6	0	12	0	35	0	28	0	5	5	18	20		3.4	6.5	3.3	15	320	520	4	31
LMHP8LUU	LMHP8L-A	8	-0.013	15	-0.013	45	-0.013	32	-0.013	5	5	21	24		3.4	6.5	3.3	15	430	780	4	53
LMHP10LUU	LMHP10L-A	10	0	19	0	55	0	40	0	6	6	25	29		4.5	8	4.4	15	580	1100	4	105
LMHP12LUU	LMHP12L-A	12	-0.010	21	0	57	-0.3	42	-0.3	6	6	27	32		4.5	8	4.4	15	650	1200	4	100
LMHP13LUU	LMHP13L-A	13	-0.016	23	-0.016	61	-0.016	43	-0.016	6	6	29	33		4.5	8	4.4	15	810	1570	4	130
LMHP16LUU	LMHP16L-A	16	0	28	0	70	0	48	0	6	6	34	31	22	4.5	8	4.4	15	1230	2350	5	187
LMHP20LUU	LMHP20L-A	20	0	32	0	80	0	54	0	8	8	38	36	24	5.5	9.5	5.4	20	1400	2750	5	260
LMHP25LUU	LMHP25L-A	25	-0.012	40	0	112	-0.019	62	-0.019	8	8	46	40	32	5.5	9.5	5.4	20	1560	3140	6	515
LMHP30LUU		30	0	45	0	123	-0.4	74	-0.4	10	10	51	49	35	6.6	11	6.5	20	2940	5490	6	655

★1 Dynamic load rating is based on the nominal life of 50km
 In case of 100km, C on the table need to be divided by 1.26
 Ex) 50km basic dynamic load rating(C) of LMHP12L = 650N
 100km basic dynamic load rating(C₁₀₀) of LMHP12L = 650/1.26 = 515.87N

★2 Based on the weight of resin retainer

★3 Main unit : mm

★4 1N ≈ 0.102kgf

linear bearing LMFM SERIES



PART NUMBER		WORKING BORE DIAMETER		D		L		D ₁		ℓ	H	PCD	d ₁	d ₂	h	SQUARENESSE ※(μm)*	BASIC LOAD RATING(N)		NO. OF BALL ROW	WEIGHT (gf) ^{*2}
Resin	Steel	dr. (mm)	CLEAR NCE (mm)	mm	CLEAR NCE (mm)	mm	CLEAR NCE (mm)	mm	CLEAR NCE (mm)								DYNAMIC (C) ^{*1}	STATIC (Co)		
LMFM6UU	LMFM6-A	6		12	0	35		28		15	5	20	3.4	6.5	3.3	15	320	520	4	31
LMFM8UU	LMFM8-A	8		15	-0.013	45		32		20	5	24	3.4	6.5	3.3	15	430	780	4	53
LMFM10UU	LMFM10-A	10		19		55		40		24.5	6	29	4.5	8	4.4	15	580	1100	4	105
LMFM12UU	LMFM12-A	12	0	21	-0.010	57	0	42	-0.3	25.5	6	32	4.5	8	4.4	15	650	1200	4	100
LMFM13UU	LMFM13-A	13		23	0	61		43		27.5	6	33	4.5	8	4.4	15	810	1570	4	130
LMFM16UU	LMFM16-A	16		28	-0.016	70		48	-0.2	32	6	38	4.5	8	4.4	15	1230	2350	5	187
LMFM20UU	LMFM20-A	20		32		80		54		36	8	43	5.5	9.5	5.4	20	1400	2750	5	260
LMFM25UU	LMFM25-A	25	0	40	-0.012	112	0	62	-0.019	52	8	51	5.5	9.5	5.4	20	1560	3140	6	515
LMFM30UU		30		45		123		74		56.5	10	60	6.6	11	6.5	20	2490	5490	6	655
LMFM35UU		35		52		135		82		62.5	10	67	6.6	11	6.5	25	2650	6470	6	970
LMFM40UU		40	0	60	-0.015	154	0	96	-0.022	70.5	13	78	9	14	8.6	25	3430	8040	6	1560
LMFM50UU		50		80		192		116		89.5	13	98	9	14	8.6	25	6080	15900	6	3500
LMFM60UU		60	0	90	-0.020	211	0	134	-0.025	96.5	18	112	11	17.5	10.8	30	7650	20000	6	4500

Part Number Notation

LMFM 20 UU - A N S



- SAMICK Circular Middle Flanged Linear Bushing
- Nominal Shaft Diameter
- Linear Bushing Long Type (for high load)

Blank	No Seal
UU	Both Side Seal
U	One Side Seal

- Retainer (material)

Blank	Resin Retainer(Standard)
A	Steel Retainer(High temperature) *1

- Outer-sleeves (by corrosion resistance)

Blank	Standard(SUJ2)
N	Electroless nickel plating
R	Raydent treatment

- Ball type (material)

Blank	High carbon bearing steel ball(Standard)
S	Stainless steel ball

Drawing

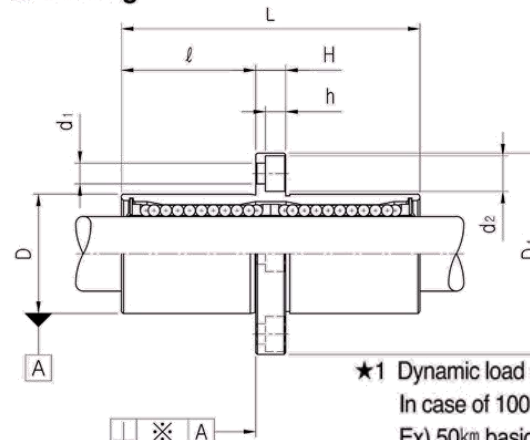

*1 Steel retainer applicable from LMFM6 to LMFM25 only

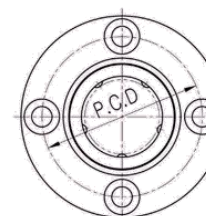

- ★1 Dynamic load rating is based on the nominal life of 50km
In case of 100km, C on the table need to be divided by 1.26
Ex) 50km basic dynamic load rating(C) of LMFM12 = 650N
100km basic dynamic load rating(C₁₀₀) of LMFM12 = 650/1.26 = 515.87N
- ★2 Based on the weight of resin retainer
- ★3 Main unit : mm
- ★4 1N ≒ 0.102kgf

linear bearing LMKM SERIES



PART NUMBER		WORKING BORE DIAMETER		D		L		D ₁		ℓ	H	PCD	K	d ₁	d ₂	h	SQUAR ENESS ※(μ) [*]	BASIC LOAD RATING(N)		NO. OF BALL ROW	WEIGHT (gf) ^{★2}
Resin	Steel	dr. (mm)	CLEAR NCE (mm)	mm	CLEAR NCE (mm)	mm	CLEAR NCE (mm)	mm	CLEAR NCE (mm)									DYNAMIC (C) ^{★1}	STATIC (Co)		
LMKM6UU	LMKM6-A	6	0	12	0	35	0	28	0	15	5	20	22	3.4	6.5	3.3	15	320	520	4	31
LMKM8UU	LMKM8-A	8		15	-0.013	45		32		20	5	24	25	3.4	6.5	3.3	15	430	780	4	53
LMKM10UU	LMKM10-A	10		19	0	55		40		24.5	6	29	30	4.5	8	4.4	15	580	1100	4	105
LMKM12UU	LMKM12-A	12		21	0	57		42		25.5	6	32	32	4.5	8	4.4	15	650	1200	4	100
LMKM13UU	LMKM13-A	13		23	0	61		43		27.5	6	33	34	4.5	8	4.4	15	810	1570	4	130
LMKM16UU	LMKM16-A	16		28	0	70		48		32	6	38	37	4.5	8	4.4	15	1230	2350	5	187
LMKM20UU	LMKM20-A	20	0	32	0	80	0	54	0	36	8	43	42	5.5	9.5	5.4	20	1400	2750	5	260
LMKM25UU	LMKM25-A	25		40	0	112		62		52	8	51	50	5.5	9.5	5.4	20	1560	3140	6	515
LMKM30UU		30		45	0	123		74		56.5	10	60	58	6.6	11	6.5	20	2490	5490	6	655
LMKM35UU		35	0	52	0	135	0	82	0	62.5	10	67	64	6.6	11	6.5	25	2650	6470	6	970
LMKM40UU		40		60	0	154		96		70.5	13	78	75	9	14	8.6	25	3430	8040	6	1560
LMKM50UU		50		80	0	192		116		89.5	13	98	92	9	14	8.6	25	6080	15900	6	3500
LMKM60UU		60	90	0	211	134	96.5	18	112	106	11	17.5	10.8	30	7650	20000	6	4500			

LMKM 20 UU - A N S

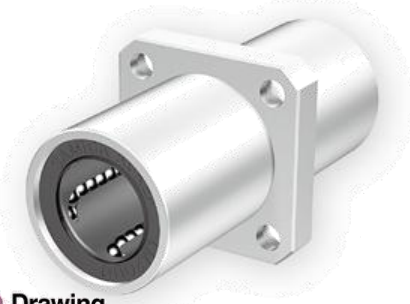

● Drawing

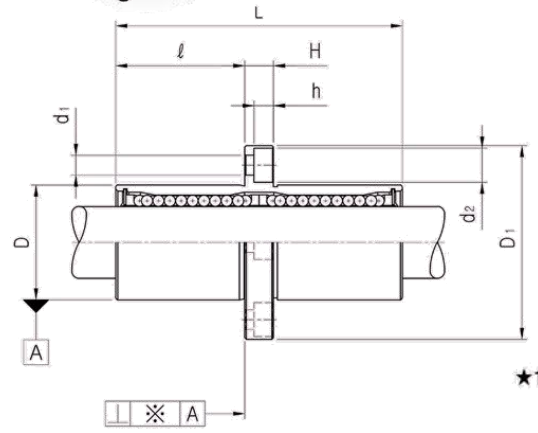

- SAMICK Square Middle Flanged Linear Bushing
- Nominal Shaft Diameter
- Linear Bushing Long Type (for high load)

Blank	No Seal
UU	Both Side Seal
U	One Side Seal

- Retainer (material)

Blank	Resin Retainer(Standard)
A	Steel Retainer(High temperature) ^{★1}

- Outer-sleeves (by corrosion resistance)

Blank	Standard(SUJ2)
N	Electroless nickel plating
R	Raydent treatment

- Ball type (material)

Blank	High carbon bearing steel ball(Standard)
S	Stainless steel ball

★1 Steel retainer applicable from LMKM6 to LMKM25 only

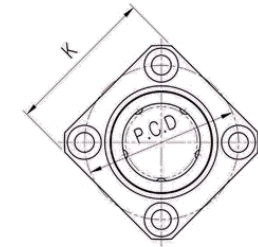

- ★1 Dynamic load rating is based on the nominal life of 50km
In case of 100km, C on the table need to be divided by 1.26
Ex) 50km basic dynamic load rating(C) of LMKM12 = 650N
100km basic dynamic load rating(C₁₀₀) of LMKM12 = 650/1.26 = 515.87N
- ★2 Based on the weight of resin retainer
- ★3 Main unit : mm
- ★4 1N ≅ 0.102kgf

linear bearing LMHM SERIES



PART NUMBER		WORKING BORE DIAMETER		D		L		D ₁		ℓ	H	W	A	F	d ₁	d ₂	h	SQUARENESSE ※(μm)*	BASIC LOAD RATING(N)		NO. OF BALL ROW	WEIGHT (gf)*2		
Resin	Steel	dr. (mm)	CLEAR NCE (mm)	mm	CLEAR NCE (mm)	mm	CLEAR NCE (mm)	mm	CLEAR NCE (mm)										DYNAMIC (C)*1	STATIC (Co)				
LMHM6UU	LMHM6-A	6	0 -0.010	12	0	35	0 -0.2	28	0 -0.2	15	5	18	20	3.4	6.5	3.3	15	320	520	4	31			
LMHM8UU	LMHM8-A	8		15	-0.013	45		32		20	5	21	24	3.4	6.5	3.3	15	430	780	4	53			
LMHM10UU	LMHM10-A	10		19	55	40		24.5		6	25	29	4.5	8	4.4	15	580	1100	4	105				
LMHM12UU	LMHM12-A	12		21	57	0 -0.3		42		25.5	6	27	32	4.5	8	4.4	15	650	1200	4	100			
LMHM13UU	LMHM13-A	13		23	61	0 -0.16		43		27.5	6	29	33	4.5	8	4.4	15	810	1570	4	130			
LMHM16UU	LMHM16-A	16		28	70	48		32		6	34	31	22	4.5	8	4.4	15	1230	2350	5	187			
LMHM20UU	LMHM20-A	20		32	80	54		36		8	38	36	24	5.5	9.5	5.4	20	1400	2750	5	260			
LMHM25UU	LMHM25-A	25		0 -0.012	40	0 -0.019		112		0 -0.4	62	52	8	46	40	32	5.5	9.5	5.4	20	1560	3140	6	515
LMHM30UU		30		45	123	74		56.5		10	51	49	35	6.6	11	6.5	20	2490	5490	6	655			

LMHM 20 UU - A N S



- SAMICK Oval Middle Flanged Linear Bushing
- Nominal Shaft Diameter
- Linear Bushing Long Type (for high load)

Blank	No Seal
UU	Both Side Seal
U	One Side Seal

- Retainer (material)

Blank	Resin Retainer(Standard)
A	Steel Retainer(High temperature) *1

- Outer-sleeves (by corrosion resistance)

Blank	Standard(SUJ2)
N	Electroless nickel plating
R	Raydent treatment

- Ball type (material)

Blank	High carbon bearing steel ball(Standard)
S	Stainless steel ball

*1 Steel retainer applicable from LMHM6 to LMHM25 only

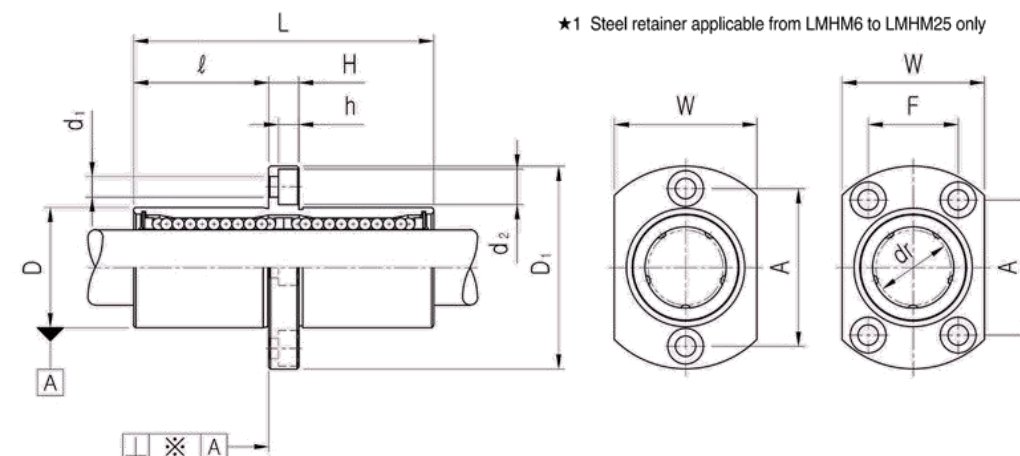

- ★1 Dynamic load rating is based on the nominal life of 50km
In case of 100km, C on the table need to be divided by 1.26
Ex) 50km basic dynamic load rating(C) of LMHM12 = 650N
100km basic dynamic load rating(C₁₀₀) of LMHM12 = 650/1.26 = 515.87N
- ★2 Based on the weight of resin retainer
- ★3 Main unit : mm
- ★4 1N ≈ 0.102kgf



Pictures





CONTACT



Address: 3/5, Shankarlal Jain Street, Nehru Nagar, Chrompet, Chennai-60044, India.



Mobile: +91 9629777210
Tel: +91 9629777210



E-mail: sriball.h@gmail.com

THANKS